

REVISIONS

REV	DESCRIPTION	DATE	APPROVED
XX	XX	MO/DY/YR	XXX

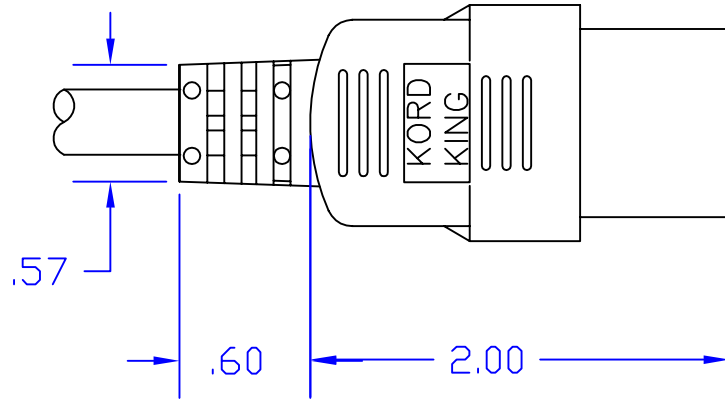
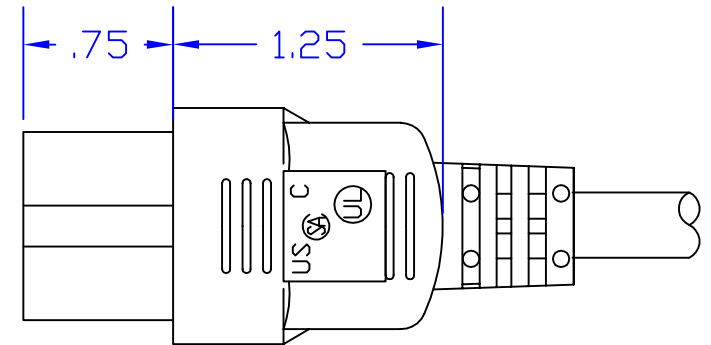
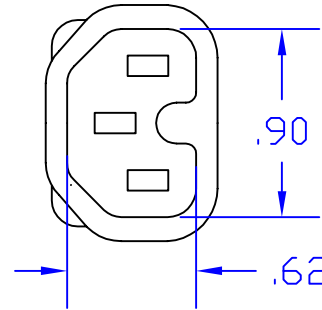
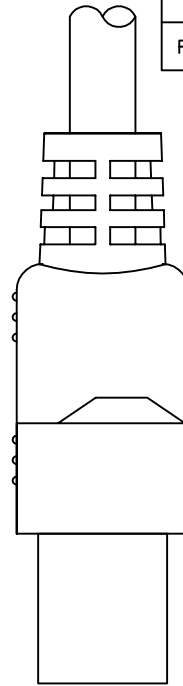
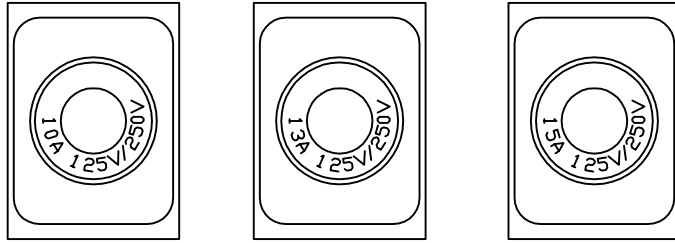

I.E.C-320 C-15

PROPRIETARY INFORMATION
KORD KING, INC.
ALL RIGHTS RESERVED

THIS DOCUMENT CONTAINS CONFIDENTIAL AND PROPRIETARY INFORMATION OF KORD KING AND IT'S RECEIPT OR POSSESSION DOES NOT CONVEY ANY RIGHTS TO REPRODUCE, DISCLOSE IT'S CONTENTS, OR TO MANUFACTURE, USE OR SELL ANYTHING IT MAY DESCRIBE. REPRODUCTION, DISCLOSURE, OR USE WITHOUT SPECIFIC WRITTEN AUTHORIZATION OF KORD KING IS STRICTLY FORBIDDEN.

TOLERANCES

FRACTIONAL ± 1/8
2 PLACE DEC. ± 0.060
3 PLACE DEC. ± 0.030

MATERIAL SPEC

PLUG: PVC BLACK
WIRE:

KORD KING, INC.

KK 10000 - C15

SIZE A	FSCM NO.	DWG NO. C-15	REV XX
SCALE NONE	DRAWN BY: AD DATE DWN: 2/ 23/2016		SHEET 1 OF 1