

REVISIONS			
REV	DESCRIPTION	DATE	APPROVED
XX	XX	MO/DY/YR	XXX

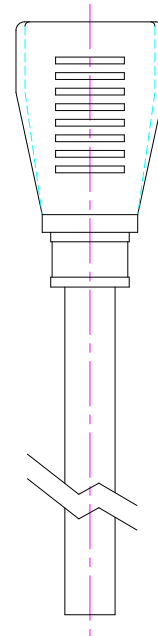
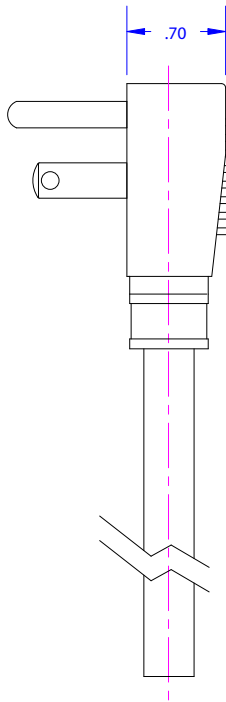
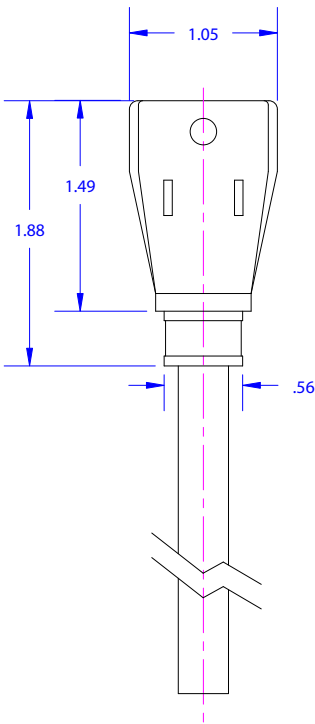

PROPRIETARY INFORMATION  
KORD KING, INC.  
ALL RIGHTS RESERVED

THIS DOCUMENT CONTAINS CONFIDENTIAL AND PROPRIETARY INFORMATION OF KORD KING AND ITS RECEIPT OR POSSESSION DOES NOT CONVEY ANY RIGHTS TO REPRODUCE, DISCLOSE ITS CONTENTS, OR TO MANUFACTURE, USE OR SELL ANYTHING IT MAY DESCRIBE. REPRODUCTION, DISCLOSURE, OR USE WITHOUT SPECIFIC WRITTEN AUTHORIZATION OF KORD KING IS STRICTLY FORBIDDEN.

TOLERANCES FRACTIONAL ± 1/8 2 PLACE DEC. ± 0.060 3 PLACE DEC. ± 0.030		<b>KORD KING, INC.</b>			
MATERIAL SPEC MAT'L: PVC COMPOUND GRADE: THICK:					
SIZE <b>A</b>	FSCM NO.	DWG NO. <b>KK8000</b>	REV <b>XX</b>		
SCALE NONE	DRAWN BY: NICK DATE DWR: 08/27/03	SHEET	1 OF 1		