

REVISIONS

REV	DESCRIPTION	DATE	APPROVED
A	15-50 RANGEPLUG	2/29/16	AD

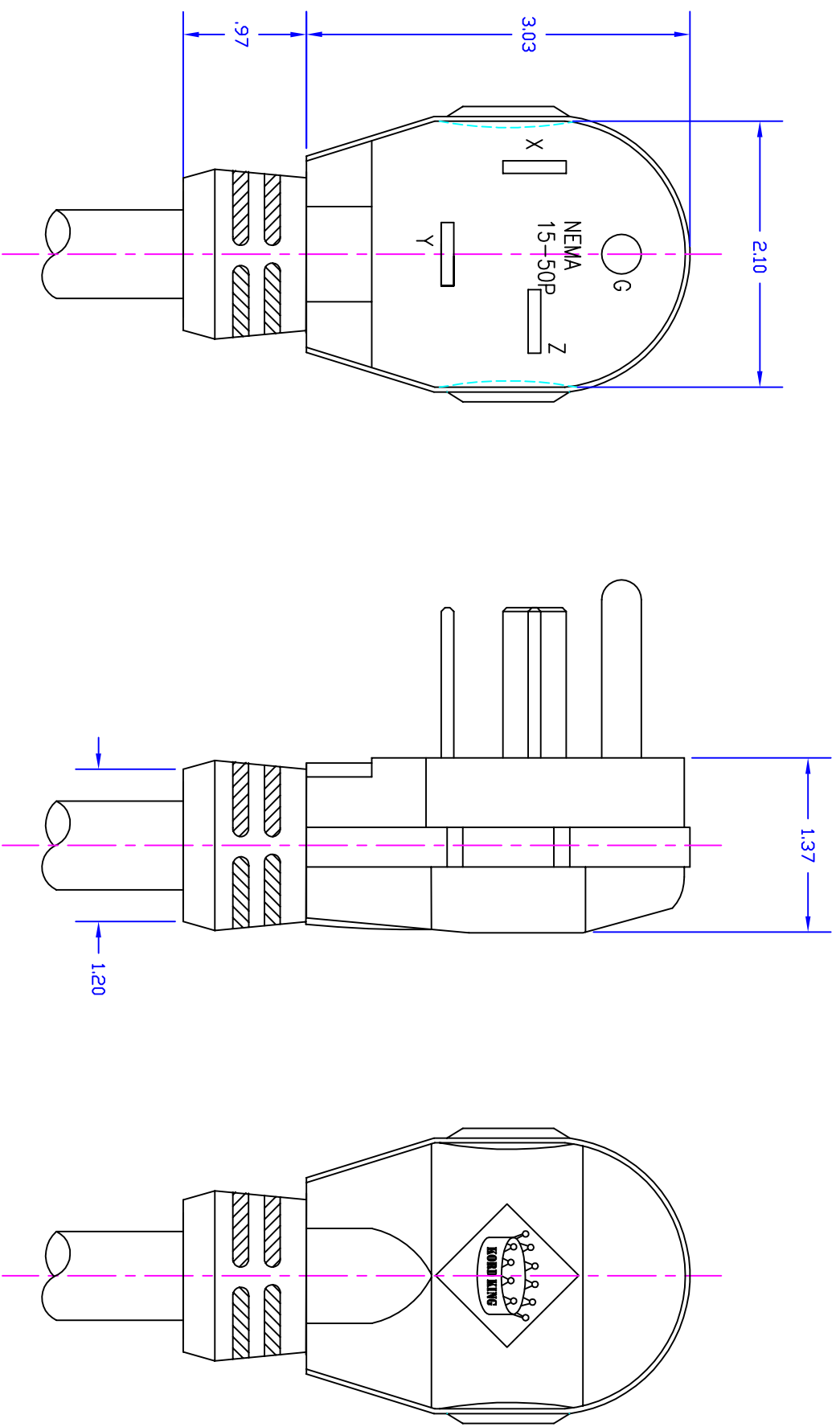

PROPRIETARY INFORMATION
KORD KING, INC.

ALL RIGHTS RESERVED
THIS DOCUMENT CONTAINS CONFIDENTIAL AND PROPRIETARY INFORMATION OF KORD KING AND IT'S RECEIPT OR POSSESSION DOES NOT CONVEY ANY RIGHTS TO REPRODUCE, DISCLOSE IT'S CONTENTS, OR TO MANUFACTURE, USE OR SELL ANYTHING IT MAY DESCRIBE. REPRODUCTION, DISCLOSURE, OR USE WITHOUT SPECIFIC WRITTEN AUTHORIZATION OF KORD KING IS STRICTLY FORBIDDEN.

TOLERANCES

MATERIAL SPEC

MAT'L:
GRADE:
THICK:

KORD KING, INC.

MOLDED PLUG
NEMA 15-50P

SIZE	FSCM NO.	DWG NO.	REV
A		KK15-50P	XX

SCALE NONE DRAWN BY: 2/29/16 SHEET 1 OF 1