

REVISIONS

REV	DESCRIPTION	DATE	APPROVED
A	14-30P MOLDED PLUG	12/15/2011	NDB

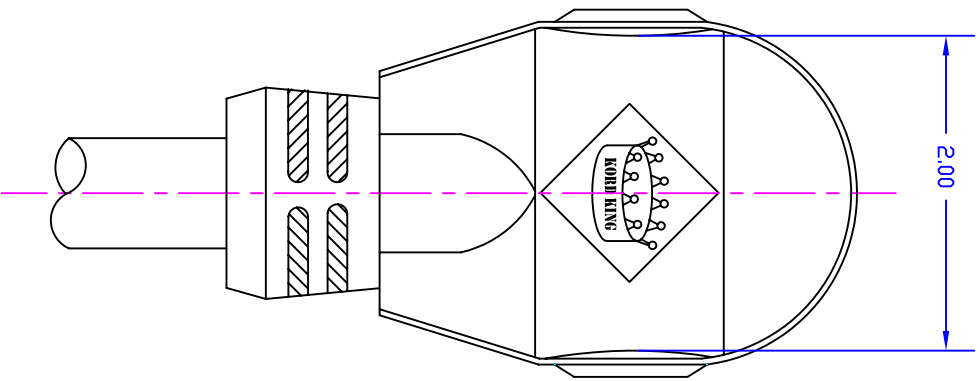
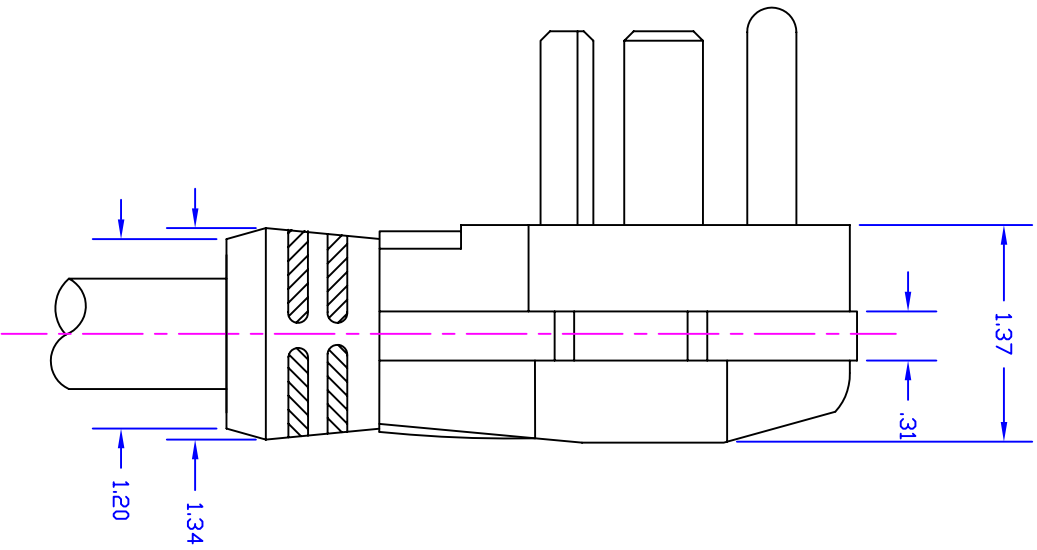
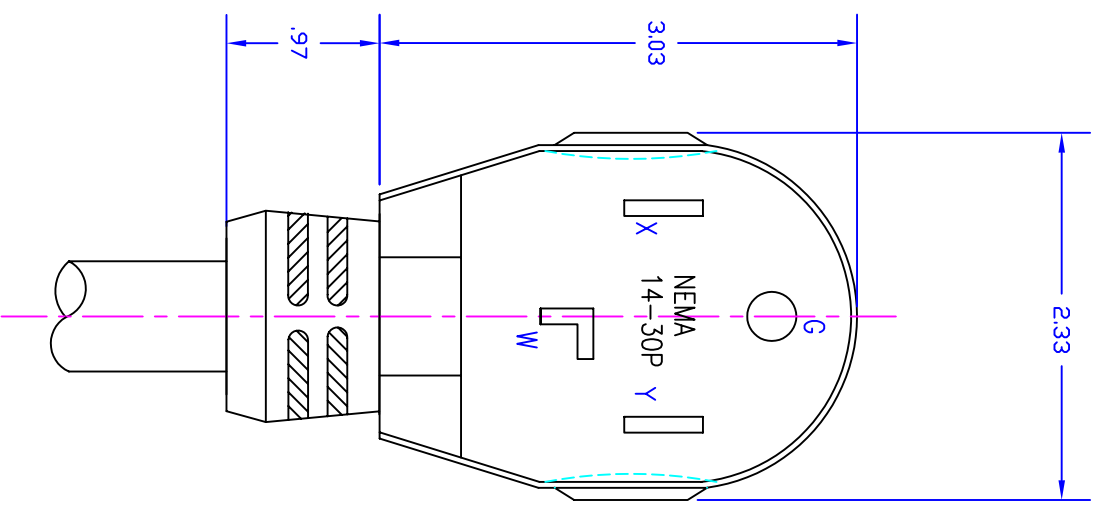

PROPRIETARY INFORMATION
KORD KING, INC.

ALL RIGHTS RESERVED
THIS DOCUMENT CONTAINS CONFIDENTIAL AND PROPRIETARY INFORMATION OF KORD KING AND IT'S RECEIPT OR POSSESSION DOES NOT CONVEY ANY RIGHTS TO REPRODUCE, DISCLOSE IT'S CONTENTS, OR TO MANUFACTURE, USE OR SELL ANYTHING IT MAY DESCRIBE, REPRODUCTION, DISCLOSURE, OR USE WITHOUT SPECIFIC WRITTEN AUTHORIZATION OF KORD KING IS STRICTLY FORBIDDEN.

TOLERANCES

MATERIAL SPEC

MAT'L: PVC

GRADE:

THICK:

KORD KING, INC.

MOLDED PLUG
NEMA 14-30P

SIZE	FSCM NO.	DWG NO.	REV
A		KK14-30P	A

SCALE NONE DRAWN BY: 04/18/06 SHEET 1 OF 1