

| REVISIONS | | | |
|-----------|--|----------|----------|
| REV | DESCRIPTION | DATE | APPROVED |
| XX | XX | MO/DY/YR | XXX |

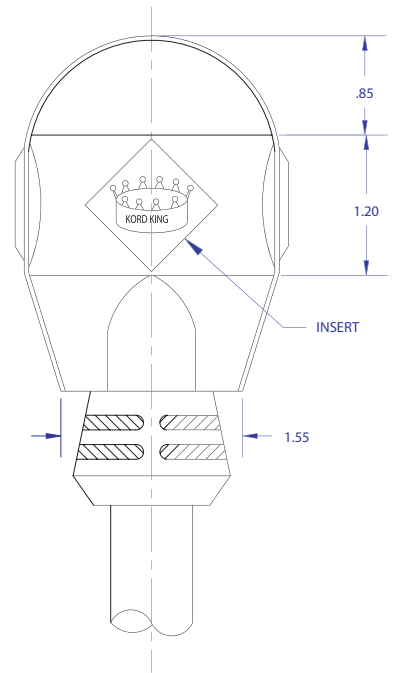
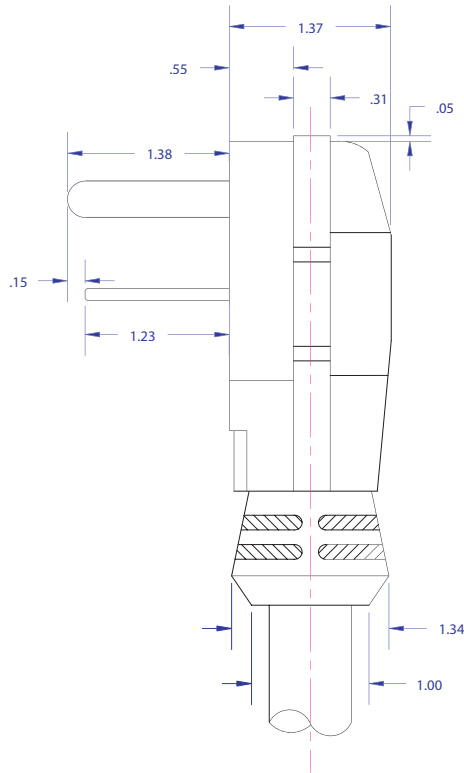
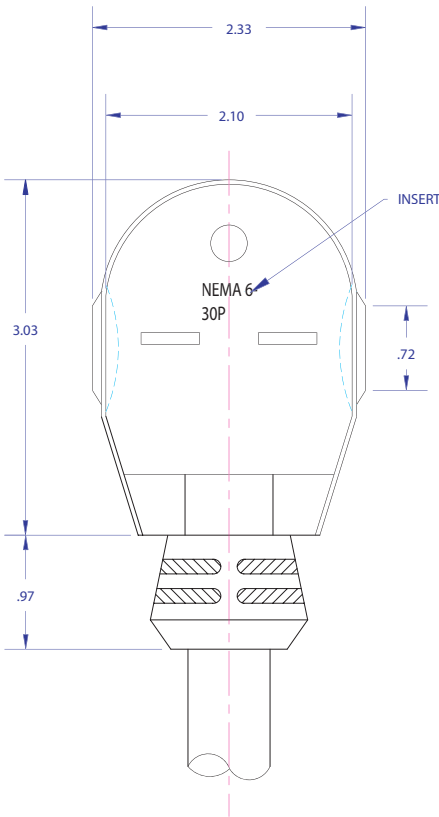

PROPRIETARY INFORMATION
KORD KING, INC.
ALL RIGHTS RESERVED

THIS DOCUMENT CONTAINS CONFIDENTIAL AND PROPRIETARY INFORMATION OF KORD KING AND ITS RECEIPT OR POSSESSION DOES NOT CONVEY ANY RIGHTS TO REPRODUCE, DISCLOSE ITS CONTENTS, OR TO MANUFACTURE, USE OR SELL ANYTHING IT MAY DESCRIBE. REPRODUCTION, DISCLOSURE, OR USE WITHOUT SPECIFIC WRITTEN AUTHORIZATION OF KORD KING IS STRICTLY FORBIDDEN.

TOLERANCES
FRACTIONAL ± 1/64
2 PLACE DEC. ± 0.010
3 PLACE DEC. ± 0.005

MATERIAL SPEC
MATL: PVC
GRADE:
THICK:

KORD KING, INC.

MOLDED PLUG
NEMA 6-30P

| | | | |
|-------|----------|--------------------------------------|--------------|
| SIZE | FSCM NO. | DWG NO. | REV |
| A | | KK-6-30P | XX |
| SCALE | NONE | DRAWN BY: 04/19/06 DATE DWN: NICK | SHEET 1 OF 1 |