

| REVISIONS | | | |
|-----------|--|----------|----------|
| REV | DESCRIPTION | DATE | APPROVED |
| XX | XX | MO/DY/YR | XXX |

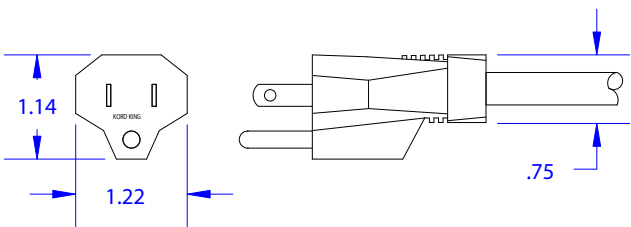
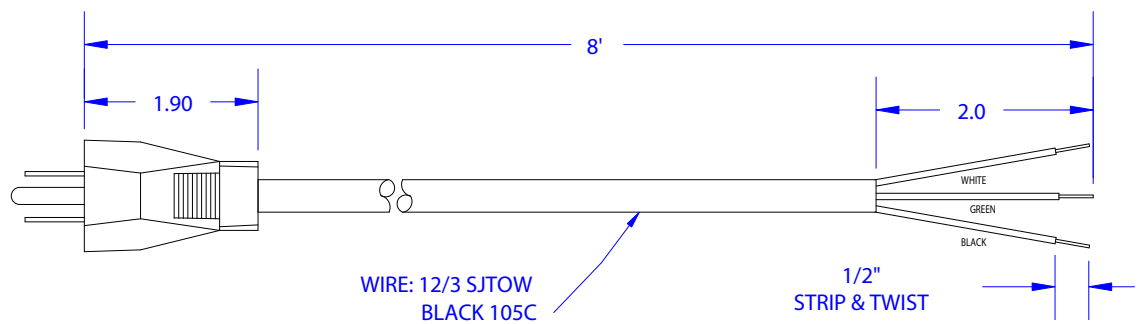

PROPRIETARY INFORMATION
KORD KING, INC.
ALL RIGHTS RESERVED

THIS DOCUMENT CONTAINS CONFIDENTIAL AND PROPRIETARY INFORMATION OF KORD KING AND ITS RECEIPT OR POSSESSION DOES NOT CONVEY ANY RIGHTS TO REPRODUCE, DISCLOSE ITS CONTENTS, OR TO MANUFACTURE, USE OR SELL ANYTHING IT MAY DESCRIBE. REPRODUCTION, DISCLOSURE, OR USE WITHOUT SPECIFIC WRITTEN AUTHORIZATION OF KORD KING IS STRICTLY FORBIDDEN.

| | | | | | |
|--------------------------|--|------------------------|----------|-------------------------------------|--------------|
| TOLERANCES | | KORD KING, INC. | | | |
| FRACTIONAL $\pm 1/8$ | | | | | |
| 2 PLACE DEC. ± 0.060 | | STOCK CORD | | | |
| 3 PLACE DEC. ± 0.030 | | 5-15P BFP PLUG | | | |
| MATERIAL SPEC | | SIZE | FSCM NO. | DWG NO. | REV |
| WIRE: 12/3 SJTOW BLACK | | A | | 1230080 | XX |
| 105°C | | SCALE | NONE | DRAWN BY: NOB DATE DWR: 03/12/02 | SHEET 1 OF 1 |